



DESCRIPTION AND APPLICATIONS

The Model 603TR is a hand-held dynamic microphone, designed for high articulation speech transmission under high ambient noise. The 603TR is the result of continuous study of the needs of the communications industry and it uniquely meets the specialized requirements of airline, two-way radio and industrial applications. The 603TR is a transistorized pressure gradient microphone utilizing two sound entrances for reduction of interfering ambient noise. Stated simply, if sound pressure and phase are reasonably identical at both sound entrances, cancellation occurs. If, however, the sound originates in close proximity to one sound entrance (i.e. ¼ - ½ inch) and more distant to the other sound entrance, then a pressure and phase differential will exist and little cancellation will occur. The 603TR is unexcelled at discriminating between near and distant sounds for maximum ambient noise rejection.

The compact two-stage transistor amplifier is specially stabilized and will operate uniformly from +158°F down to - 40°F. Output of the transistor amplifier is designed to plug directly into inputs designed for carbon microphones. The internal potentiometer allows the output level to be adjusted, using a jeweler's screwdriver, thus precisely controlling output to the transmitter. The 603TR provides extremely reliable, crisp, clear speech reproduction with high sensitivity and low distortion.

SPECIFICATIONS

Type:	Transistorized dynamic
Frequency Response:	200 to 4,000 Hz
Impedance:	Matches 100 to 500 ohm carbon input
Polar Pattern:	Pressure gradient (Differential close-talking)
Output Level:	Adjustable up to - 44 db with normal speech ¼" from front of microphone. (0 db = 1 volt/dyne/cm ²)
Diaphragm:	Electro-Voice Acoustalloy®
Case Material:	High impact phenolic
Finish:	Black
Amplifier Gain:	48 db
Current Drain:	22 ma at 14 volts
Rated Supply Voltage:	24 volts nominal (14 to 29 volts)
Maximum Undistorted Output:	4.0 (with 24 v supply and 250 ohm load)
Dimensions:	2¼" W x 3-9/16" H x 1-3/8" D
Net Weight:	7½ ounces
Connector:	PJ-068 or XLR-4-12C
Cable:	3 or 4 conductor coiled cord, 5' extended.
Switch:	DPST wiping contact leaf switch or DPST (with common ground)
Accessories Available:	Microphone holder (magnetic hold-down)
Temperature Range:	- 40° C (- 40° F) to + 70° C (+158° F)
FAA Approval:	TSO-C58

OVERHAUL INSTRUCTIONS

1. **Special Tools.** None.
2. **Disassembly.** (See Figure 8)
 - a. Begin disassembly by removing the four screws holding the case back.
 - b. Do not remove the head subassembly unless it is necessary to replace the head. If it is necessary to replace this component, proceed as indicated in steps c and d.
 - c. With an eyedropper, feed Esso Solvent No. 1 at the sides and bottom of the head assembly. Allow the solvent time to dissolve cement holding head to front case. Then gently pry the head assembly loose, using a screwdriver.
 - d. With the head assembly removed, it is possible to unsolder all leads and replace the head.
 - e. The switch assembly should be disassembled carefully.
 - f. Do not unsolder leads to switch unless necessary for replacement of cable.

Cleaning:

- a. Thoroughly clean all dust and dirt from microphone by first using dry, compressed air to dislodge dirt from inaccessible corners. Then clean each part with a lint-free cloth or brush, slightly dampened with dry cleaning solvent, Federal Specification P-S-661. Do not get solvent on head diaphragm.
- b. Remove pits from switch contacts by burnishing.

4. Inspection:

- a. Inspect switch contacts for signs of excessive wear.
- b. Examine unit for damaged or dried-out wiring or sleeving. Check all soldering connections for good contacts.
- c. Check cable for signs of damage such as cuts or cracks.

5. Repair and Replacement:

- a. Replace any part which is damaged.
- b. Check resistance across the head with an ohmmeter. It should be about 25 ohms. In addition, a distinct click from the microphone element should be heard when the circuit to the ohmmeter is made or interrupted. If it is not, replace head as described in the reassembly procedure.

6. **Lubrication:** Clean and add small drop of light machine oil to each end of switch actuator spring.

7. Reassembly:

- a. Reassembly is the reverse of disassembly, noting special instructions given below:
- b. If the head assembly was removed, proceed to install it as follows:

- c. Apply a film of Minnesota Mining and Manufacturing Cement, EC871 to the four edges on the raised portion of the front cover of the microphone head.
- d. When the cement is tacky, mount head in place inside the front case. Allow cement to dry for about 10 minutes. Solder the leads in place across the head.

8. Test Procedure (See Figure 1 or Figure 2)

9. Check of Switch Operation: (4 wire connection) Check the operation of the switch as follows:

- a. With the switch released, check the resistance between the white and green leads. It should be infinite.
- b. Check the resistance between the red and black leads. It should be infinite.
- c. Depress switch and check resistance between white and green leads. It should be zero.
- d. Depress switch and check resistance between red and black leads. It should be from 1000 to 10,000 ohms depending on meter polarity.

10. Check of Switch Operation: (3 wire connection) Check the operation of the switch as follows:

- a. With the switch released, check the resistance between the black and white leads. It should be infinite.
- b. Check the resistance between the black and red leads. It should be infinite.
- c. Depress switch and check resistance between black and white leads. It should be zero.
- d. Depress switch and check resistance between black and red leads. It should be about 1000 to 10,000 ohms depending on meter polarity.

11. Check of Microphone Output. The best procedure for testing the microphone is to compare its output with one known to be operating properly, using the test set-up shown in Figure 3, or Figure 4. Check the output voltage as follows:

- a. Depress microphone switch and adjust voltage to obtain 12 to 14 volts on DC meter.
- b. Hold the test microphone about one-quarter inch from the mouth and talk at normal speech level with microphone switch depressed. An output of about 0.031 volt should be obtained.

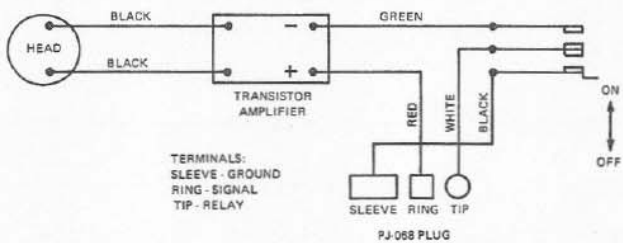

Figure 1 - Wiring Diagram (3 wire connection)

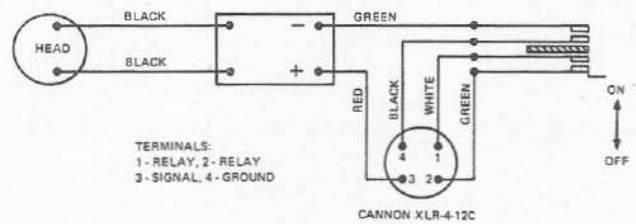

Figure 2 - Wiring Diagram (4 wire connection)

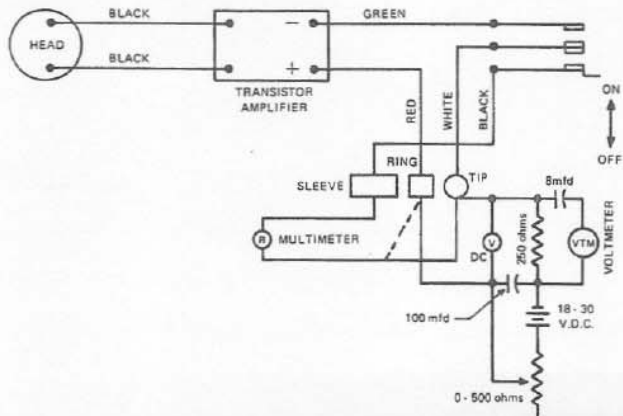

Figure 3 - Test Set-up (3 wire connection)

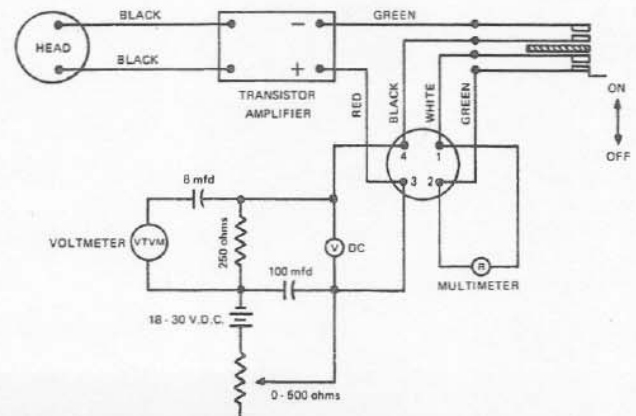

Figure 4 - Test Set-up (4 wire connection)

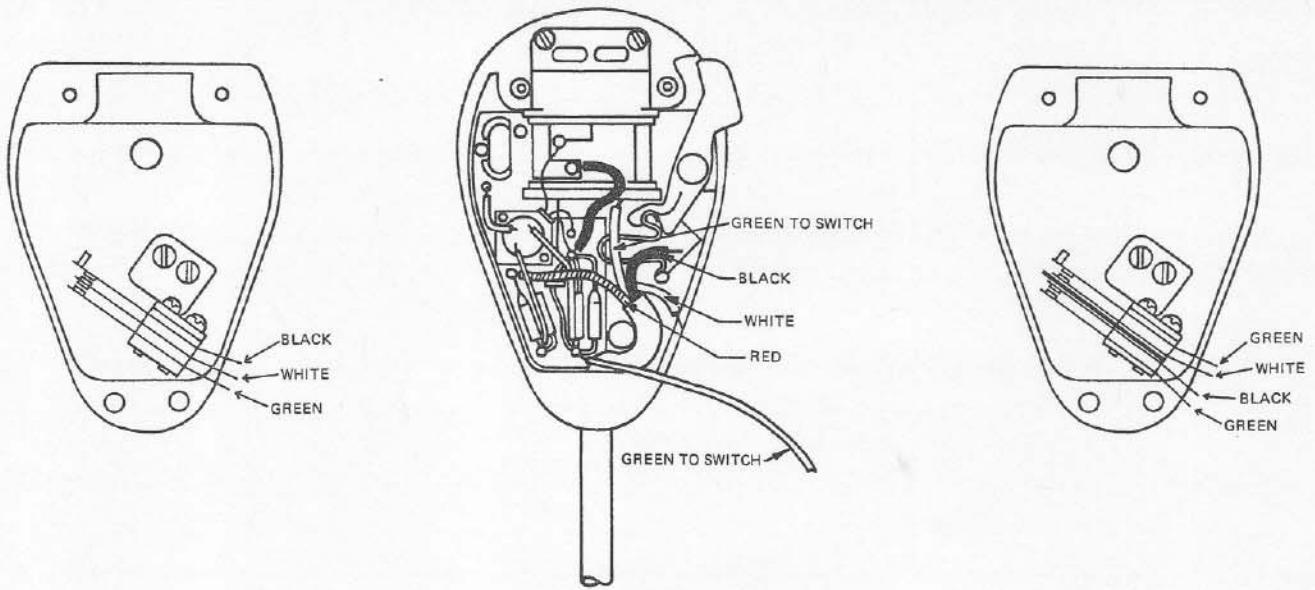

Fig. 5-Case Back (3 wire connection)

Fig. 6-Case Front

Fig. 7-Case Back (4 wire connection)

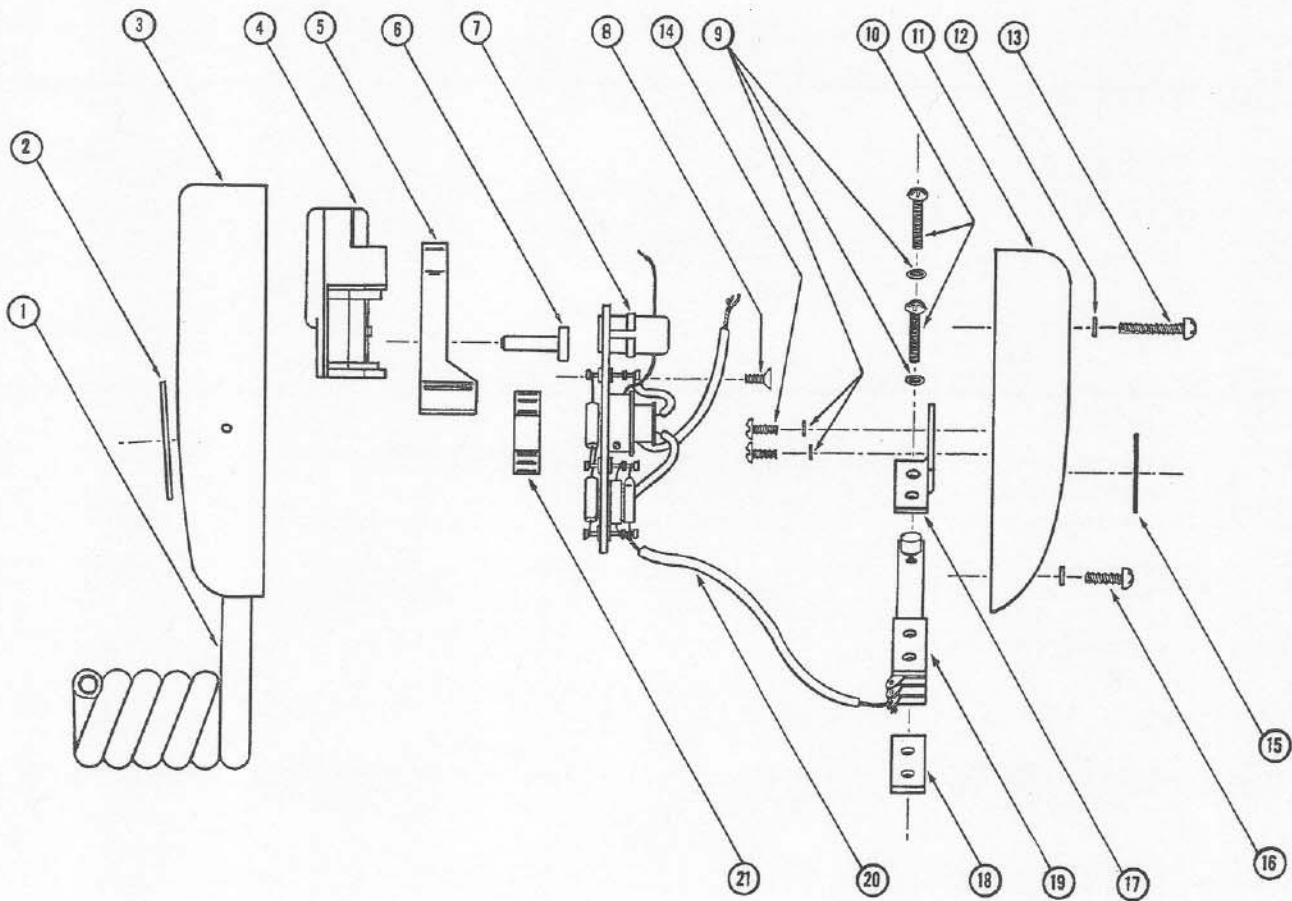

Figure 8 - Model 603TR Assembly

SPARE PARTS LIST MODEL 603TR

FIG. NO.	QUANT. USED	PART NO.	NOMENCLATURE
1	1	A8111 or 8160	Cable Sub Assembly (4 Conductor) Cable Sub Assembly (3 Conductor)
2	1	A48054	Nameplate
3	1	C73333	Case, Front
4	1	613-2108	Microphone Head
5	1	A73336	Actuator
6	1	20417	Drive Pin, Actuator
7	1	8360	Amplifier, sub assembly
8	1	C60023	Screw, 2-56 x 3/16" fl. Hd. Phillips steel Cad. plate
9	4	4067	Lockwasher, No. 3, Nickel, Black, Phos. Br.
10	2	B60128	Screw, 3-48 x 1/2" Rd. Hd. Phil. Stl., Chem. Blk.
11	1	A73334	Case, Back
12	4	A4084	Lockwasher, No. 4 Chem. Black, Stl.
13	2	B60329	Screw, 4-4 x 9/16 Rd. Hd. Phil. Stl. Cad. plate
14	2	E60023	Screw, 2-56 x 3/16 Bd. Hd., Phillips, stl. Cad. plate
15	1	48051	Nameplate
16	2	B60325	Screw, 4-40 x 5/16" Rd. Hd. Phil. Stl. Chem. Blk.
17	1	73335	Bracket, Switch
18	1	7505	Plate, Switch
19	1	56016 or 56010	Switch, leaf (4 terminal) Switch, leaf (3 terminal)
20	1	1612	Wire, No. 27, Stranded, 2" Green
21	1	1975	Spring, Actuator

